

THREE & FOUR POINT FLEXURE FIXTURE 12" SPAN - 2" WIDE - PIN SUPPORTS CENTER FINDING SCALES

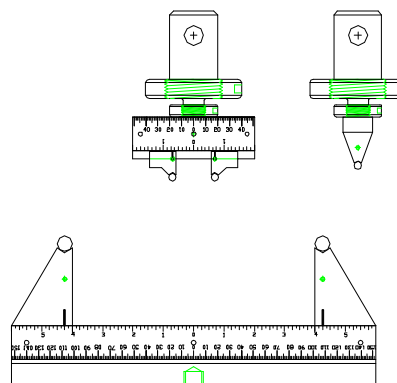

Specimen:	Width	Any width up to 2"
	Thickness	Any thickness up to 2"
	Length	Any length up to 12"
	Support Spans	Any span from 0.5" to 8"
	4-point Head	Any span from 0.5" to 4"
	Loading Radii	Quick change floating loading pins. 0.500" (supports) - 0.250" (heads) diameter
Fixture:	Construction	Stainless steel
	Temperature	-240 to 600°F (-152 to 318°C)
	Mounting	5/8" -18 threaded couplings
	Capacity	8,000 lbs
	Dimensions	Assembled - 13" x 3" x 9" approximately
	Weight	25 lbs approximately
	Standard	Manufactured in accordance with ASTM D790

Model No. ASTM.D0790.20 - Three & Four Point Flexure Fixture for Plastic. Specimen widths up to 2.0" with supports continuously adjustable from 1/2" up to 12". 5/8"-18 threaded couplings supplied for mounting purposes. Fixture constructed of stainless steel in accordance with ASTM D790.

Support Base - 12" long by 2" wide with a T-slot running the length of the base. The upper and lower surfaces are ground flat and parallel. The support block separation is measured along a center finding scale on the the front surface of the support base.

Specimen Supports - 2" wide by 3" tall with alignment rails which fit in the T-slotted support base. The supports are supplied with 0.500" diameter loading pins which are held in alignment grooves with O-rings. The center position of the loading pin is indicated by a scribe line which runs down the side of the support to the center finding scale. The supports are free to slide anywhere along the support base and may be reversed for short and long spans.

Three & Four Point Loading Head - Four point head is 2" wide with two adjustable loading pin supports. The loading rail allows the pin supports to be adjusted to any loading span from 1/2" to 3". The pin supports are channeled to insure proper alignment to the loading rail. The pin supports are supplied with 0.250" diameter pins which are held in an alignment groove with O-rings. The center positions of the loading pins are scribed in the pin support which runs along a center finding scale on the loading rails.

MODEL NO. ASTM.D0790.20

FLEXURE

ACCESSORIES

Upper and lower fixture attachment is supplied with 5/8"-18 female coupling (Common adapter sizes include:

Model No. M01S27 - 1/2" Male Clevis (Type B) to 5/8" -18 Threaded Stud
Model No. M02S27 - 5/8" Male Clevis (Type C) to 5/8" -18 Threaded Stud
Model No. M03S27 - 1.25" Male Clevis (Type D) to 5/8" -18 Threaded Stud
Model No. M12S27 - 12mm Male Clevis to 5/8" -18 Threaded Stud Adapter
Model No. S36S27 - 1" -14 to 5/8" -18 Threaded Step Stud
Model No. LN27 - 5/8" -18 Threaded Locking Nut with Knurled OD

SPARE PARTS

Model No. SPA.D0790.2001- Extra 1/2" Diameter Roller Sets of (4)
Model No. SPA.D0790.2002- Extra 3/8" Diameter Roller Sets of (4)
Model No. SPA.D0790.2003- Extra 1/4" Diameter Roller Sets of (4)

REFERENCE DOCUMENT AND TEST METHOD SCOPE:

Scope <http://www.astm.org/Standards/D790.htm>
ASTM D790-10

Standard Test Methods for Flexural Properties of Unreinforced and Reinforced Plastics and Electrical Insulating Materials

1.1 These test methods cover the determination of flexural properties of unreinforced and reinforced plastics, including high-modulus composites and electrical insulating materials in the form of rectangular bars molded directly or cut from sheets, plates, or molded shapes. These test methods are generally applicable to both rigid and semirigid materials. However, flexural strength cannot be determined for those materials that do not break or that do not fail in the outer surface of the test specimen within the 5.0 % strain limit of these test methods. These test methods utilize a three-point loading system applied to a simply supported beam. A four-point loading system method can be found in Test Method D6272.

1.1.1 Procedure A, designed principally for materials that break at comparatively small deflections.

1.1.2 Procedure B, designed particularly for those materials that undergo large deflections during testing.

1.1.3 Procedure A shall be used for measurement of flexural properties, particularly flexural modulus, unless the material specification states otherwise. Procedure B may be used for measurement of flexural strength only. Tangent modulus data obtained by Procedure A tends to exhibit lower standard deviations than comparable data obtained by means of Procedure B.

1.2 Comparative tests may be run in accordance with either procedure, provided that the procedure is found satisfactory for the material being tested.

1.3 The values stated in SI units are to be regarded as the standard. The values provided in parentheses are for information only.

1.4 This standard does not purport to address all of the safety concerns, if any, associated with its use. It is the responsibility of the user of this standard to establish appropriate safety and health practices and determine the applicability of regulatory limitations prior to use.

Note 1—These test methods are not technically equivalent to ISO 178.

Extracted, with permission, from ASTM D790 Standard Test Methods for Flexural Properties of Unreinforced and Reinforced Plastics and Electrical Insulating Materials, copyright ASTM International, 100 Barr Harbor Drive, West Conshohocken, PA 19482. A copy of the complete standard may be purchased from ASTM International, www.astm.org.